

Compilers and VMs for Programming Environments Used by Scientists

José Nelson Amaral – Univ. of Alberta
(with input from Laurie Hendren and
Rahul Garg – McGill Univ.)

Why Python in Computational Chemistry?

- Easy integration of code written in C/C++;
- Composibility (reuse)
 - New students quickly get results
 - Build from existing modules, instead of building from scratch
- Easy to learn the language
- Visualization (very important)
- Drawbacks:
 - Performance of Python modules

Completing the Bridge

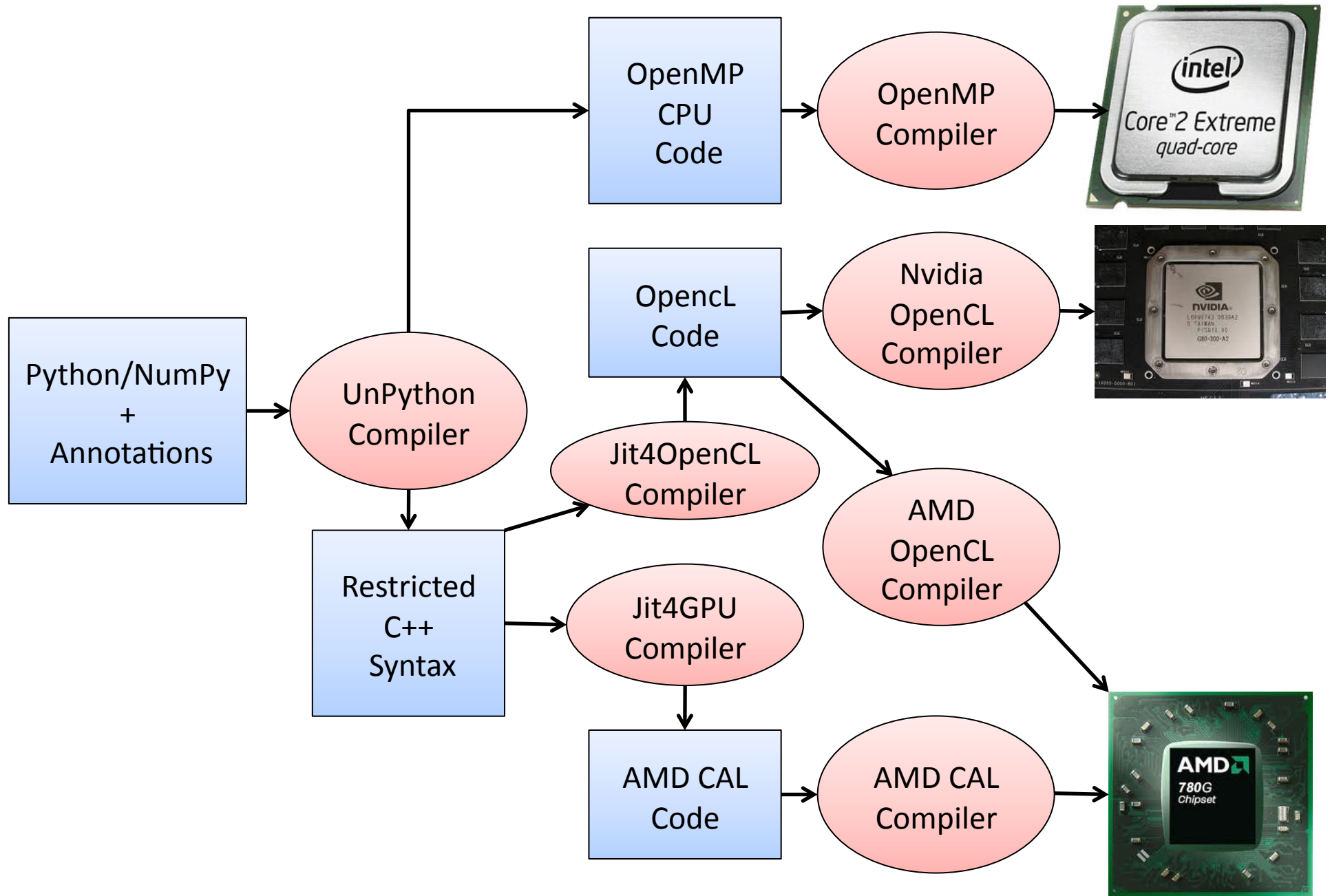

Completing the Bridge

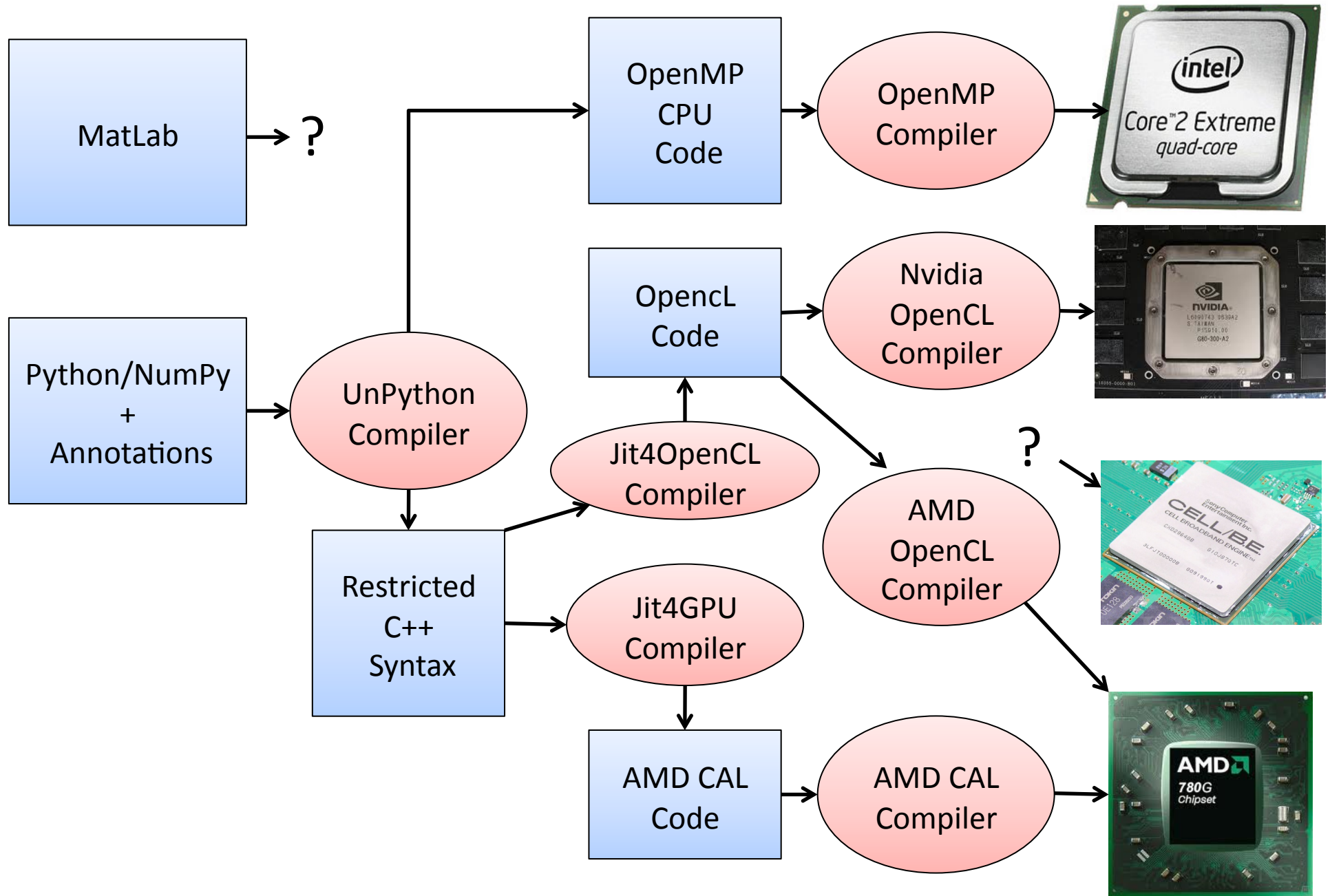

What we have

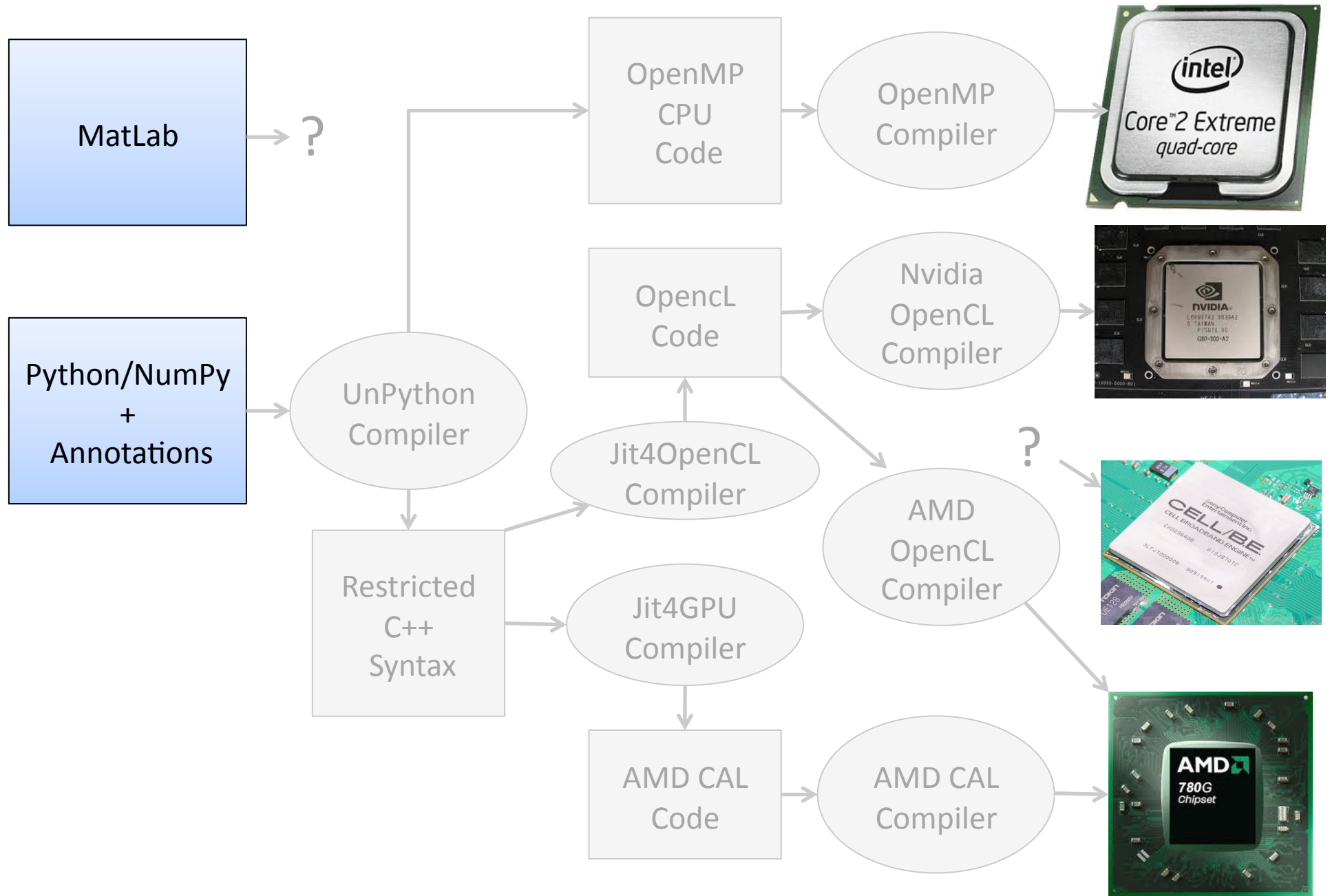

What we want

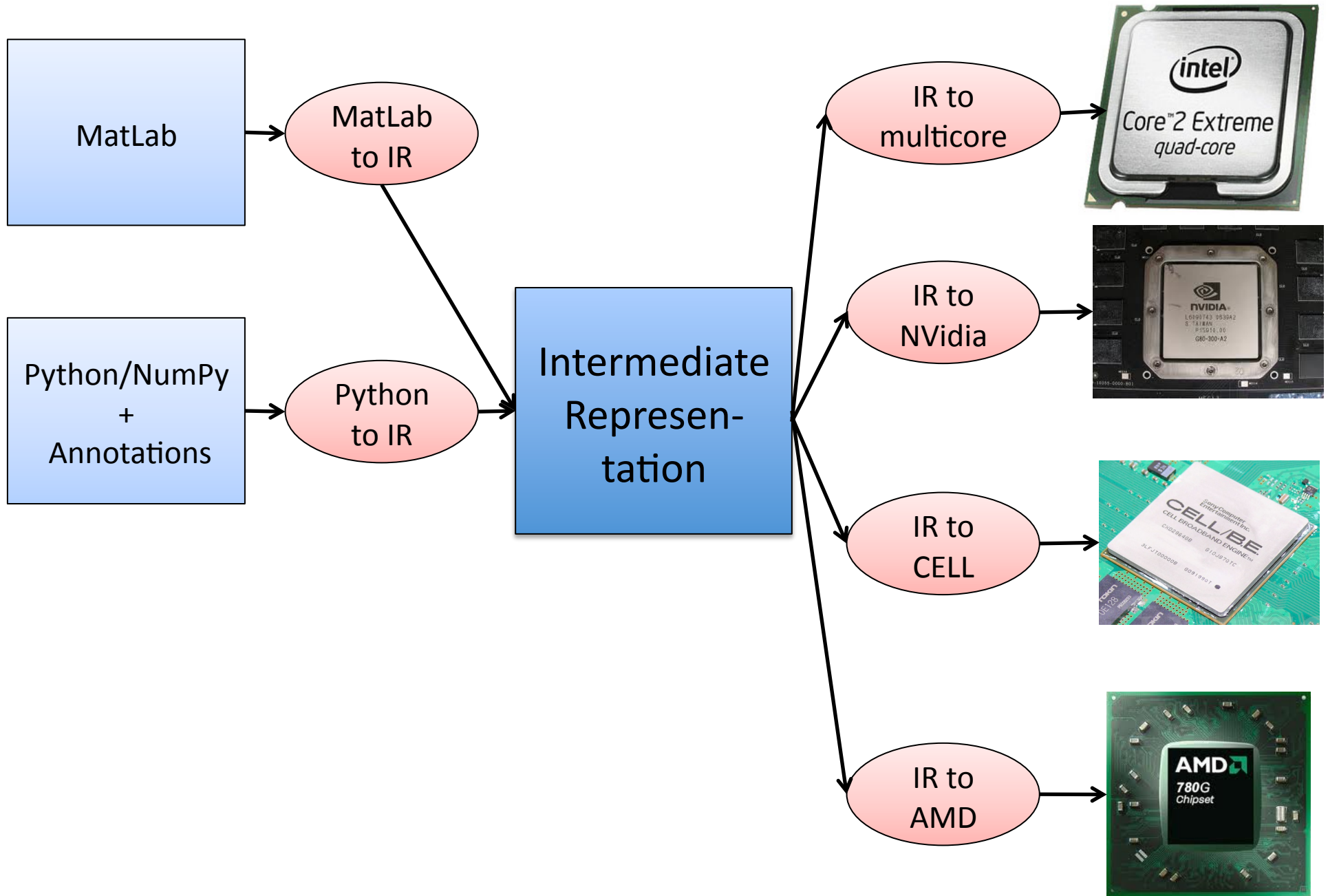

Issues with MATLAB

- No formal specification and no official publicly-available implementation
 - McLab group is creating on a best-effort specification;
- Designed for interpretation not for efficient execution;
- Many dynamic features
 - But many of those are not needed or are misused;

Goals for Hendren's group

- Create a modern and open research framework for MATLAB:
 - Focus on dynamic features that are effectively used
 - Facilitate creation of extensions for domain-specific languages
 - Create a suitable IR



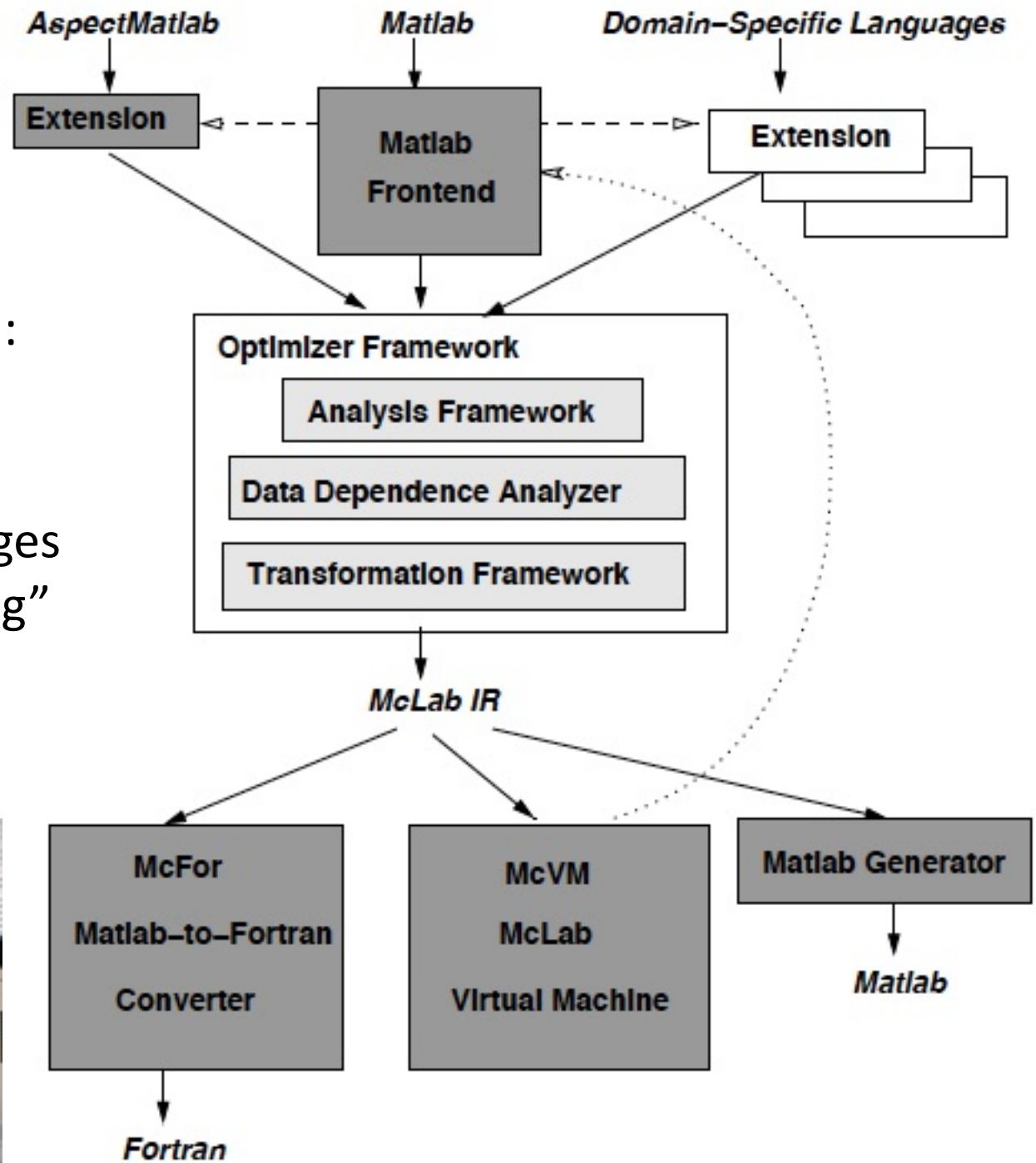

Hendren's McLab Vision:

“start with the languages that scientists are using”



Challenges

- Type inference
- Dynamic features
- Loose Language specifications
- Diverse, complex, and evolving hardware platforms